

PERFORMANCE ANALYSIS OF TRADITIONAL AND IMPROVED TRANSFORMER DIFFERENTIAL PROTECTIVE RELAYS

Armando Guzmán, Stan Zocholl, and
Gabriel Benmouyal
Schweitzer Engineering Laboratories, Inc.
Pullman, WA USA

Hector J. Altuve
Universidad Autonoma de Nuevo Leon
Monterrey, N.L., Mexico

ABSTRACT

This paper describes a new approach for transformer differential protection that ensures security for external faults, inrush, and overexcitation conditions and provides dependability for internal faults. This approach combines harmonic restraint and blocking methods with a wave shape recognition technique. First, we review the concept of transformer differential protection. We then analyze magnetizing inrush, overexcitation, and current transformer (CT) saturation phenomena as possible causes of relay misoperation. After summarizing the existing methods for discriminating internal faults from inrush and overexcitation conditions, we propose a new approach for transformer differential protection and describe the relay that is based on this approach. Finally, we compare the behavior of some of these methods for real cases of magnetizing inrush conditions.

INTRODUCTION

Three characteristics generally provide means for detecting transformer internal faults [1]. These characteristics include an increase in phase currents, an increase in the differential current, and gas formation caused by the fault arc [2], [3]. When transformer internal faults occur, immediate disconnection of the faulted transformer is necessary to avoid extensive damage and/or preserve power system stability and power quality. Three types of protection are normally used to detect these faults: overcurrent protection for phase currents, differential protection for differential currents, and gas accumulator or rate-of-pressure-rise protection for arcing faults.

Overcurrent protection with fuses or relays provided the first type of transformer fault protection [4]; it continues to be applied in small capacity transformers. Connecting an inverse-time overcurrent relay in the paralleled secondaries of the current transformers introduced the differential principle to transformer protection [4]. The percentage differential principle [5], which was immediately applied to transformer protection [4], [6], [7], provided excellent results in improving the security of differential protection for external faults with CT saturation.

This analysis will focus primarily on differential protection. Differential relays are prone to misoperation in the presence of transformer inrush currents, which result from transients in transformer magnetic flux. The first solution to this problem was to introduce an intentional time delay in the differential relay [4], [6]. Another proposal was to desensitize the relay for a given time, to override the inrush condition [6], [7]. Others suggested adding a voltage signal to restrain [4] or to supervise the differential relay [8].

Researchers quickly recognized that the harmonic content of the differential current provided information that helped differentiate faults from inrush conditions. Kennedy and Hayward proposed a differential relay with only harmonic restraint for bus protection [9]. Hayward [10]

and Mathews [11] further developed this method by adding percentage differential restraint for transformer protection. These early relays used all the harmonics to restrain. With a relay that used only the second harmonic to block, Sharp and Glassburn introduced the idea of harmonic blocking instead of restraining [12].

Many modern transformer differential relays use either harmonic restraint or blocking methods. These methods ensure relay security for a very high percentage of inrush and overexcitation cases. However, these methods do not work in cases with very low harmonic content in the operating current. Common harmonic restraint or blocking, introduced by Einval and Linders [13], increases relay security for inrush, but could delay operation for internal faults combined with inrush in the nonfaulted phases.

Transformer overexcitation is another possible cause of differential relay misoperation. Einval and Linders proposed the use of an additional fifth-harmonic restraint to prevent such misoperations [13]. Others have proposed several methods based on wave shape recognition to distinguish faults from inrush and have applied these methods in transformer relays [14]–[17]. However, these techniques do not identify transformer overexcitation conditions.

This paper describes a new approach for transformer differential protection using current-only inputs. The approach ensures security for external faults, inrush, and overexcitation conditions, and dependability for internal faults. It combines harmonic restraint and blocking methods with a wave shape recognition technique. The new method uses even harmonics for restraint and also blocks operation using the dc component and the fifth harmonic.

TRANSFORMER DIFFERENTIAL PROTECTION

Percentage restraint differential protective relays [5], [6] have been in service for many years. Figure 1 shows a typical differential relay connection diagram. Differential elements compare an operating current with a restraining current. The operating current (also called differential current), I_{OP} , can be obtained as the phasor sum of the currents entering the protected element:

$$I_{OP} = |I_{W1} + I_{W2}| \quad \text{Equation 1}$$

I_{OP} is proportional to the fault current for internal faults and approaches zero for any other operating (ideal) conditions.

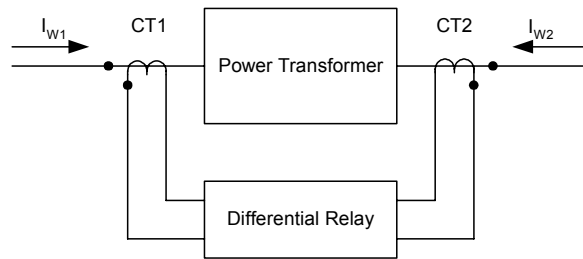

6100-001

Figure 1 Typical Differential Relay Connection Diagram

Following are the most common ways to obtain the restraining current:

$$I_{RT} = k |I_{W1} - I_{W2}| \quad \text{Equation 2}$$

$$I_{RT} = k \left(|I_{W1}| + |I_{W2}| \right) \quad \text{Equation 3}$$

$$I_{RT} = \text{Max} \left(|I_{W1}|, |I_{W2}| \right) \quad \text{Equation 4}$$

where k is a compensation factor, usually taken as 1 or 0.5.

Equation 3 and Equation 4 offer the advantage of being applicable to differential relays with more than two restraint elements.

The differential relay generates a tripping signal if the operating current, I_{OP} , is greater than a percentage of the restraining current, I_{RT} :

$$I_{OP} > \text{SLP} \cdot I_{RT} \quad \text{Equation 5}$$

Figure 2 shows a typical differential relay operating characteristic. This characteristic consists of a straight line having a slope equal to SLP and a horizontal straight line defining the relay minimum pickup current, I_{PU} . The relay operating region is located above the slope characteristic (Equation 5), and the restraining region is below the slope characteristic.

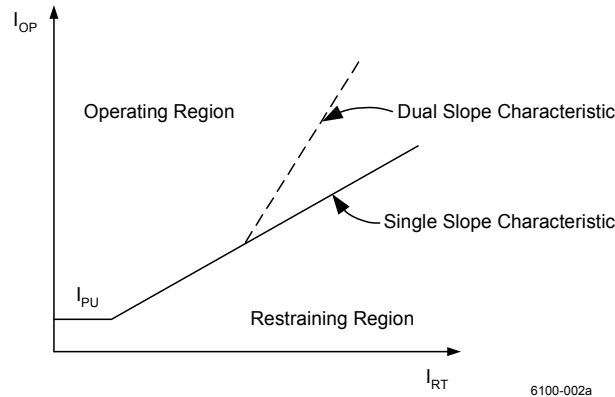

Figure 2 Differential Relay With Dual Slope Characteristic

Differential relays perform well for external faults, as long as the CTs reproduce the primary currents correctly. When one of the CTs saturates, or if both CTs saturate at different levels, false operating current appears in the differential relay and could cause relay misoperation. Some differential relays use the harmonics caused by CT saturation for added restraint and to avoid misoperations [9]. In addition, the slope characteristic of the percentage differential relay provides further security for external faults with CT saturation. A variable-percentage or dual-slope characteristic, originally proposed by Sharp and Glassburn [12], further increases relay security for heavy CT saturation. Figure 2 shows this characteristic as a dotted line.

CT saturation is only one of the causes of false operating current in differential relays. In the case of power transformer applications other possible sources of error are:

- Mismatch between the CT ratios and the power transformer ratio
- Variable ratio of the power transformer caused by a tap changer
- Phase shift between the power transformer primary and secondary currents for delta-wye connections

- Magnetizing inrush currents created by transformer transients because of energization, voltage recovery after the clearance of an external fault, or energization of a parallel transformer
- High exciting currents caused by transformer overexcitation

The relay percentage restraint characteristic typically solves the first two problems. A proper connection of the CTs or emulation of such a connection in a digital relay (auxiliary CTs historically provided this function) addresses the phase shift problem. A very complex problem is that of discriminating internal fault currents from the false differential currents caused by magnetizing inrush and transformer overexcitation.

MAGNETIZING INRUSH, OVEREXCITATION, AND CT SATURATION

Inrush or overexcitation conditions of a power transformer produce false differential currents that could cause relay misoperation. Both conditions produce distorted currents because they are related to transformer core saturation. The distorted waveforms provide information that helps to discriminate inrush and overexcitation conditions from internal faults. However, this discrimination can be complicated by other sources of distortion such as CT saturation, nonlinear fault resistance, or system resonant conditions.

Inrush Currents

The study of transformer excitation inrush phenomena has spanned more than 50 years [18]–[26]. Magnetizing inrush occurs in a transformer whenever the polarity and magnitude of the residual flux do not agree with the polarity and magnitude of the ideal instantaneous value of steady-state flux [22]. Transformer energization is a typical cause of inrush currents, but any transient in the transformer circuit may generate these currents. Other causes include voltage recovery after the clearance of an external fault or the energization of a transformer in parallel with a transformer that is already in service. The magnitudes and waveforms of inrush currents depend on a multitude of factors, and are almost impossible to predict [23]. The following summarizes the main characteristics of inrush currents:

- Generally contain dc offset, odd harmonics, and even harmonics [22], [23].
- Typically composed of unipolar or bipolar pulses, separated by intervals of very low current values [22], [23].
- Peak values of unipolar inrush current pulses decrease very slowly. Time constant is typically much greater than that of the exponentially decaying dc offset of fault currents.
- Second-harmonic content starts with a low value and increases as the inrush current decreases.
- Relay currents are delta currents (a delta winding is encountered in either the power- or current-transformer connections, or is simulated in the relay), which means that currents of adjacent windings are subtracted, and:
 - DC components are subtracted
 - Fundamental components are added at 60°
 - Second harmonics are added at 120°
 - Third harmonics are added at 180° (they cancel out), and so forth

Sonnemann et al. initially claimed that the second-harmonic content of the inrush current was never less than 16–17 percent of the fundamental [22]. However, transformer energization with reduced voltages may generate inrush currents with second-harmonic content less than 10 percent, as this paper explains later.

Transformer Overexcitation

The magnetic flux inside the transformer core is directly proportional to the applied voltage and inversely proportional to the system frequency. Overvoltage and/or underfrequency conditions can produce flux levels that saturate the transformer core. These abnormal operating conditions can exist in any part of the power system, so any transformer may be exposed to overexcitation.

Transformer overexcitation causes transformer heating and increases exciting current, noise, and vibration. A severely overexcited transformer should be disconnected to avoid transformer damage. Because it is difficult, with differential protection, to control the amount of overexcitation that a transformer can tolerate, transformer differential protection tripping for an overexcitation condition is not desirable. Use separate transformer overexcitation protection instead, and the differential element should not trip for these conditions. One alternative is a V/Hz relay that responds to the voltage/frequency ratio.

Overexcitation of a power transformer is a typical case of ac saturation of the core that produces odd harmonics in the exciting current. Figure 3 shows the exciting current recorded during a real test of a 5 kVA, 230/115 V, single-phase laboratory transformer [24]. The current corresponds to an overvoltage condition of 150 percent at nominal frequency. For comparison purposes, the peak value of the transformer nominal current is 61.5 A, and the peak value of the exciting current is 57.3 A.

Table 1 shows the most significant harmonics of the current signal depicted in Figure 3. Harmonics are expressed as a percentage of the fundamental component. The third harmonic is the most suitable for detecting overexcitation conditions, but either the delta connection of the CTs or the delta connection compensation of the differential relay filters out this harmonic. The fifth harmonic, however, is still a reliable quantity for detecting overexcitation conditions.

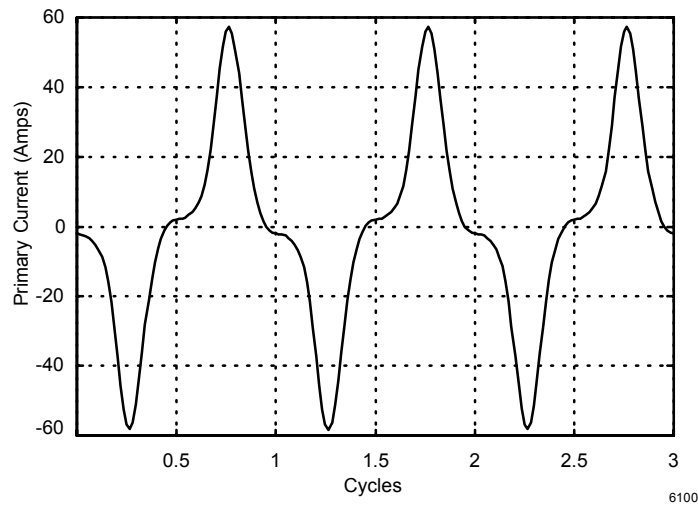

Figure 3 Exciting Current of an Overexcited Transformer; Overvoltage of 150 Percent Applied to a 5 kVA, 230/115 V Single-Phase Transformer

Table 1 Harmonic Content of the Current Signal Shown in Figure 3

Frequency Component	Magnitude (Primary Amps)	Percentage of Fundamental
Fundamental	22.5	100.0
Third	11.1	49.2
Fifth	4.9	21.7
Seventh	1.8	8.1

Einval and Linders [13] were first to propose using the fifth harmonic to restrain the transformer differential relay. They recommended setting this restraint function at 35 percent of fifth harmonic with respect to the fundamental. Figure 4 [25] shows the harmonic content of the excitation current of a power transformer as a function of the applied voltage. As the voltage increases, saturation and the exciting current increase. The odd harmonics, expressed as a percentage of the fundamental, first increase and then begin to decrease at overvoltages on the order of 115–120 percent. Setting the differential relay fifth-harmonic restraint to 35 percent ensures security for overvoltage conditions less than 140 percent. For greater overvoltages, which could destroy the transformer in a few seconds, it is desirable to have the differential relay fast tripping added to that of the transformer overexcitation relay.

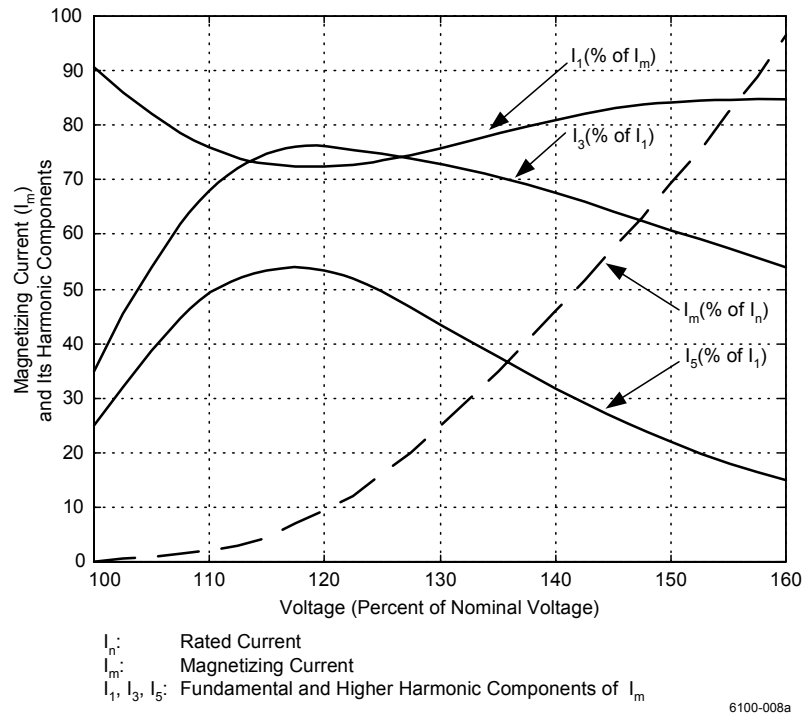

Figure 4 Harmonic Content of Transformer Exciting Current as a Function of the Applied Voltage [25]

CT Saturation

CT saturation during faults and the effect of CT saturation on protective relays have received considerable attention [26]–[31]. In the case of transformer differential protection, the effect of CT saturation is double edged. For external faults, the resulting false differential current may

produce relay misoperation. In some cases, the percentage restraint in the relay addresses this false differential current. For internal faults, the harmonics resulting from CT saturation could delay the operation of differential relays having harmonic restraint or blocking.

The main characteristics of CT saturation are the following:

- CTs reproduce faithfully the primary current for a given time after fault inception [30]. The time to CT saturation depends on several factors, but is typically one cycle or longer.
- The worst CT saturation is produced by the dc component of the primary current. During this dc saturation period, the secondary current may contain dc offset and odd and even harmonics [10], [28].
- When the dc offset dies out, the CT has only ac saturation, characterized by the presence of odd harmonics in the secondary current [9], [10], [26].

Figure 5 shows a typical secondary current waveform for computer-simulated ac symmetrical CT saturation. This figure also depicts the harmonic content of this current. The figure confirms the presence of odd harmonics and the absence of even harmonics in the secondary current.

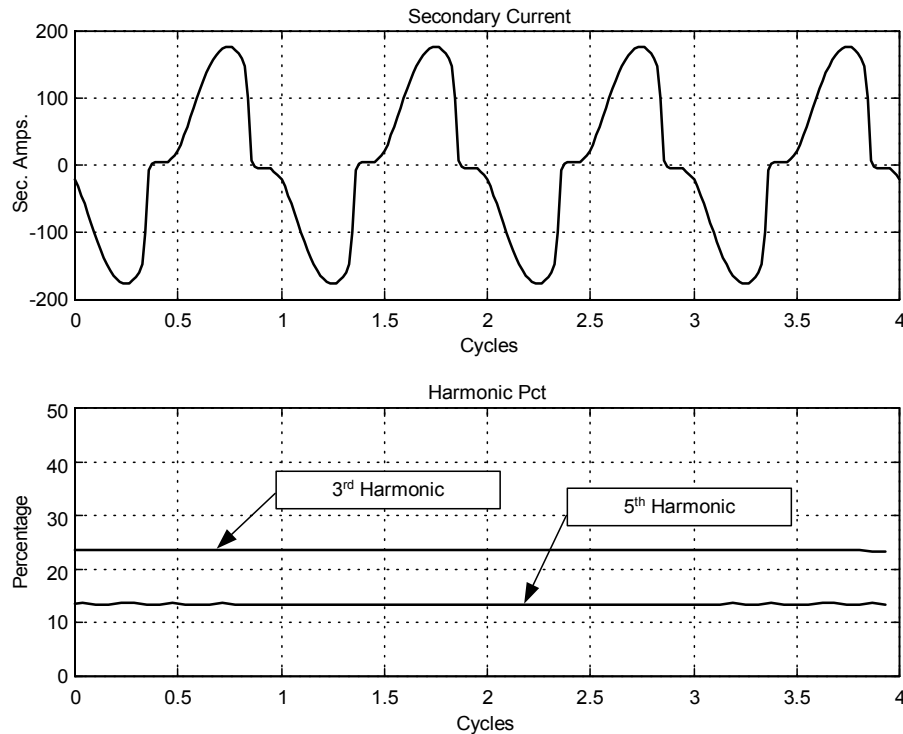

Figure 5 Typical Secondary Current for Symmetrical CT Saturation and the Harmonic Content It Contains

METHODS FOR DISCRIMINATING INTERNAL FAULTS FROM INRUSH AND OVEREXCITATION CONDITIONS

Early transformer differential relay designs used time delay [4], [6] or a temporary desensitization of the relay [6], [7] to override the inrush current. Other designs used an additional voltage signal to restrain [4] or to supervise (block) [8] the differential relay. These proposals increased

operating speed at the cost of higher complexity. Recent methods use voltage information to provide transformer protection [32]–[35]. It is recognized, however, that while an integrated digital substation protection system provides voltage information, this is not the case for a stand-alone differential relay. Adding voltage signals to such a relay requires potential transformers that are normally not available in the installation.

The current-based methods for discriminating internal faults from inrush and overexcitation conditions fall into two groups: those using harmonics to restrain or block [9]–[13] and those based on wave-shape identification [14]–[17].

Harmonic-Based Methods

We can use the harmonic content of the differential current to restrain or block the relay, providing ways to differentiate between internal faults and inrush or overexcitation conditions. The technical literature on this topic has not clearly identified the differences between restraint and blocking.

The original harmonic-restrained differential relays used all harmonics to provide the restraint function [9], [10], [11]. The resulting high level of harmonic restraint provided security for inrush conditions at the expense of operating speed for internal faults with CT saturation.

Figure 6 shows a simplified schematic diagram of a well-known transformer differential relay with harmonic restraint [36]. Auxiliary current transformers (not shown) form the operating and restraint currents of the relay. The operating current is the phasor sum of the currents entering the protected transformer (Equation 1). A through-current transformer having two primary circuits forms the restraint current for two-winding transformers. Each of the through-current transformer primary circuits is connected to the main current transformer circuits. The resulting restraint current is the phasor difference of the currents entering the transformer (Equation 2). The relay has three independent through-current transformers for three-winding transformer applications. The relay rectifies each of the secondary currents of the through-current transformers independently and then sums them to form a restraint current with the following form:

$$I_{RT} = k \left(|I_{W1}| + |I_{W2}| + |I_{W3}| \right) \quad \text{Equation 6}$$

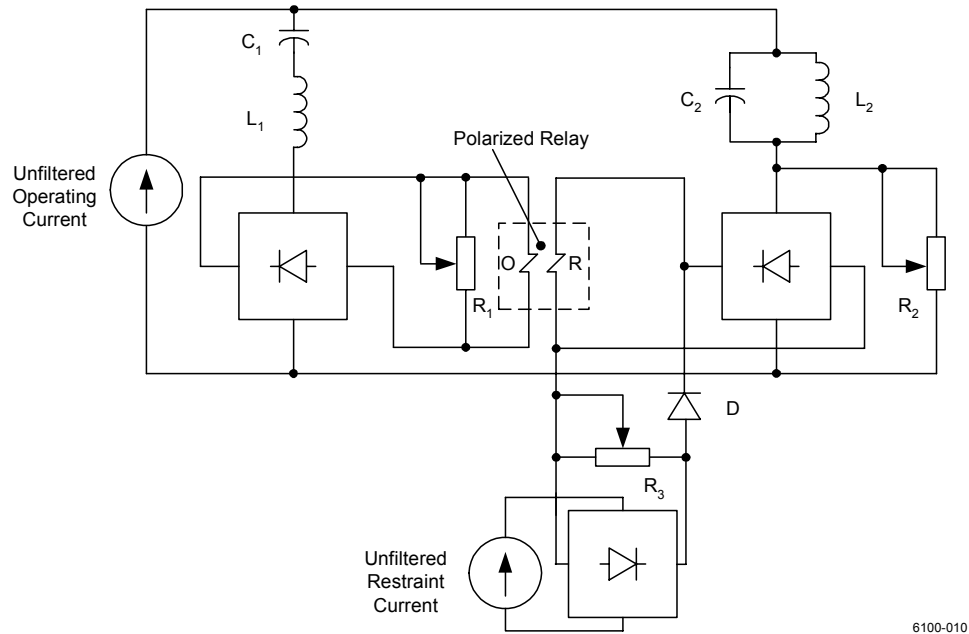

Figure 6 Transformer Differential Relay With Harmonic Restraint

The main operating unit of the transformer differential relay is a polarized relay (see Figure 6). This unit performs an amplitude comparison of the rectified currents applied to the operating, O, and restraint, R, coils. The unit trips when the current in the operating coil exceeds the current in the restraint coil.

The circuit supplying the operating coil of the polarized relay includes a band-pass series filter (L_1 , C_1) tuned to 60 Hz. The circuit supplying the restraint coil of the polarized relay contains a notch-type parallel filter (L_2 , C_2) tuned to 60 Hz. Restraint current is also supplied to the restraint coil to provide a percentage differential characteristic. As a result, the polarized unit compares the fundamental component of the operating current with a restraint signal consisting of the harmonics of the operating current plus the unfiltered restraint current.

The differential relay operating condition can be expressed as

$$I_{OP} > SLP \cdot I_{RT} + K_2 I_2 + K_3 I_3 + \dots \quad \text{Equation 7}$$

where I_{OP} represents the fundamental component of the operating current; I_2 , I_3 , ... are the higher harmonics; I_{RT} is the unfiltered restraint current; and K_2 , K_3 , ... are constant coefficients.

Resistor R_1 (see Figure 6) provides adjustment of the minimum pickup current, I_{PU} , of the differential relay (see Figure 2). Resistor R_2 controls the level of harmonic restraint in the relay. Resistor R_3 provides the slope percentage adjustment; it has three taps corresponding to the slope values of 15, 25, and 40 percent.

During transformer magnetizing inrush conditions the unfiltered operating current may contain, in addition to harmonics, a dc offset component. The band-pass filter, L_1 , C_1 , blocks the dc component, but the notch filter, L_2 , C_2 , passes the dc component, thus providing an additional temporary restraint that increases relay security for inrush.

Diode D (see Figure 6) did not appear in the initial version of this transformer differential relay [11]. For high values of the restraint current, diode D conducts and Equation 7 is valid. On the

other hand, the diode cuts off for low restraint currents, and only the operating current harmonics are applied to the restraint coil of the polarized relay. In this case the differential relay operation condition is as follows:

$$I_{OP} > K_2 I_2 + K_3 I_3 + \dots \quad \text{Equation 8}$$

The transformer differential relay also contains an instantaneous overcurrent element (not shown) that provides instantaneous tripping for heavy internal faults even if the current transformers saturate.

Einval and Linders [13] designed a three-phase differential relay with second- and fifth-harmonic restraint. This design complemented the idea of using only the second harmonic to identify inrush currents (originally proposed by Sharp and Glassburn [12]), by using the fifth harmonic to avoid misoperations for transformer overexcitation conditions.

The relay [13] includes air-gap auxiliary current transformers that produce voltage secondary signals and filter out the dc components of the input currents. A maximum voltage detector produces the percentage differential restraint voltage, so the restraint quantity is of the form shown in Equation 4. The relay forms an additional restraint voltage by summing the second- and fifth-harmonic components of a voltage proportional to the operating current. The basic operation equation for one phase can be expressed according to the following:

$$I_{OP} > SLP \cdot I_{RT} + K_2 I_2 + K_5 I_5 \quad \text{Equation 9}$$

Einval and Linders first introduced the concept of common harmonic restraint in this relay. The harmonic restraint quantity is proportional to the sum of the second- and fifth-harmonic components of the three relay elements. The relay operation equation is of the following form:

$$I_{OP} > SLP \cdot I_{RT} + \sum_{n=1}^3 (K_2 I_{2n} + K_5 I_{5n}) \quad \text{Equation 10}$$

Sharp and Glassburn [12] were first to propose harmonic blocking. Figure 7 depicts a simplified schematic diagram of the transformer differential relay with second-harmonic blocking [12]. The relay consists of a differential unit, DU, and a harmonic blocking unit, HBU. Differential relay tripping requires operation of both DU and HBU units.

In the differential unit (Figure 7 (A)) an auxiliary current transformer (not shown) forms the operating current according to Equation 1. This current is rectified and applied to the operating coil of a polarized relay unit. Auxiliary air-gap current transformers (not shown) produce secondary voltages that are proportional to the transformer winding currents. These voltages are rectified by parallel-connected rectifier bridges, which behave as a maximum voltage detector. The resulting restraint current, applied to the restraint coil of the polarized relay unit, has the form of Equation 4. The polarized relay unit performs an amplitude comparison of the operating and the restraint currents and generates the relay percentage differential characteristic (Equation 5). Resistor R_1 (see Figure 7 (A)) provides the slope percentage adjustment for the differential relay. An auxiliary saturating transformer (not shown) connected in the operating circuit provides a variable slope characteristic.

In the harmonic blocking unit (Figure 7 (B)) an auxiliary air-gap current transformer (not shown) generates a version of the operating current (Equation 1) without the dc offset component, which is blocked by the air-gap transformer. The fundamental component and higher harmonics of the operating current are passed to two parallel circuits, rectified, and applied to the operating and

restraint coils of the polarized relay unit. The circuit supplying the operating coil of the polarized relay unit includes a notch-type parallel filter (L_1, C_1) tuned to 120 Hz. The circuit supplying the restraint coil of the polarized relay contains a low-pass filter (L_3) combined with a notch filter (L_2, C_2) tuned to 60 Hz. The series combination of both filters passes the second harmonic and rejects the fundamental component and remaining harmonics of the operating current. As a result, the polarized relay compares an operating signal formed by the fundamental component, plus the third and higher order harmonics of the operating current, with a restraint signal that is proportional to the second harmonic of the operating current. The operating condition of the harmonic blocking unit, HBU, can be expressed as follows:

$$I_{OP} + K_3 I_3 + K_4 I_4 + \dots > K_2 I_2 \quad \text{Equation 11}$$

Figure 7 (C) shows a simplified diagram of the relay contact logic. Transient response of the filters for inrush currents with low second-harmonic content can cause differential relay misoperation. A time-delay auxiliary relay, T, shown in Figure 7 (C) prevents this misoperation.

The relay also includes an instantaneous overcurrent unit (not shown) to provide fast tripping for heavy internal faults.

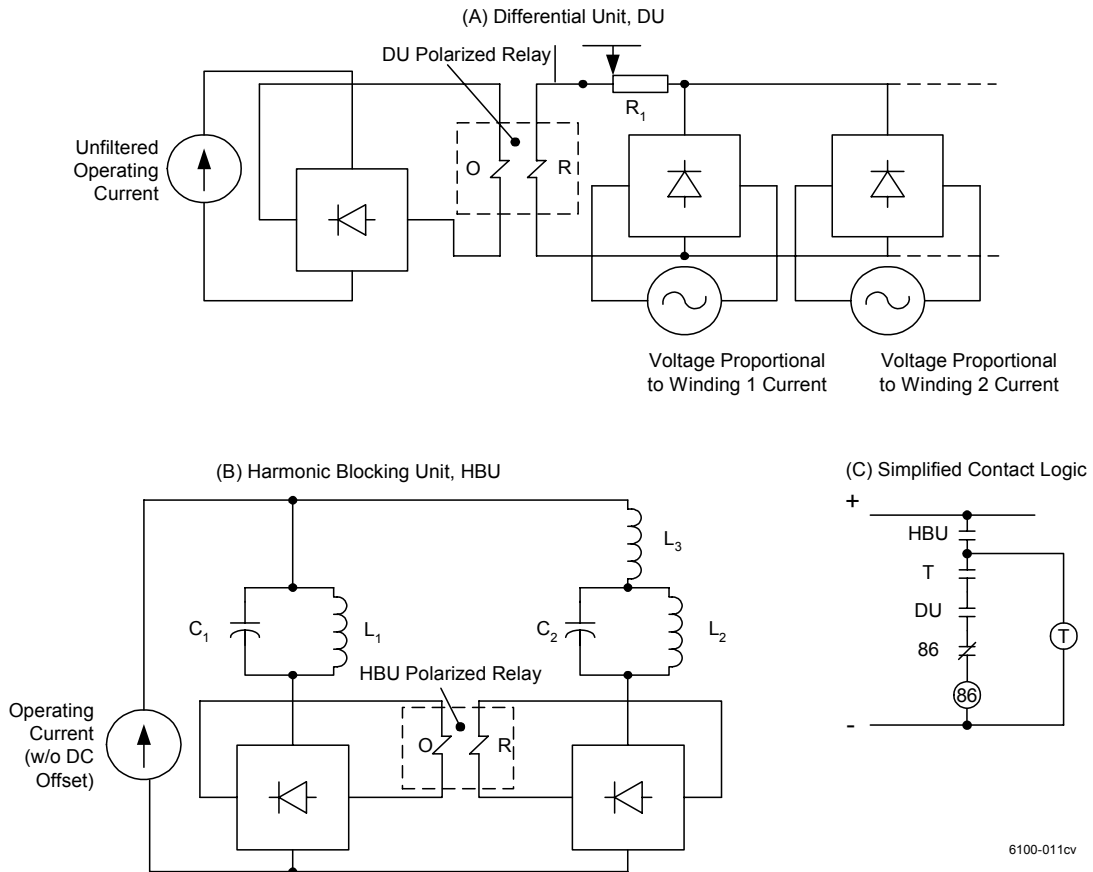

Figure 7 Transformer Differential Relay With Second-Harmonic Blocking

Typically, digital transformer differential relays use second- and fifth-harmonic blocking logic. Figure 8 (A) shows a logic diagram of a differential element having second- and fifth-harmonic blocking. A tripping signal requires fulfillment of Equation 5, without fulfillment of the following blocking conditions (Equation 12 and Equation 13):

$$I_{OP} < K_2 I_2 \quad \text{Equation 12}$$

$$I_{OP} < K_5 I_5 \quad \text{Equation 13}$$

Figure 8 (B) depicts the logic diagram of a differential element using second-and fifth-harmonic restraint.

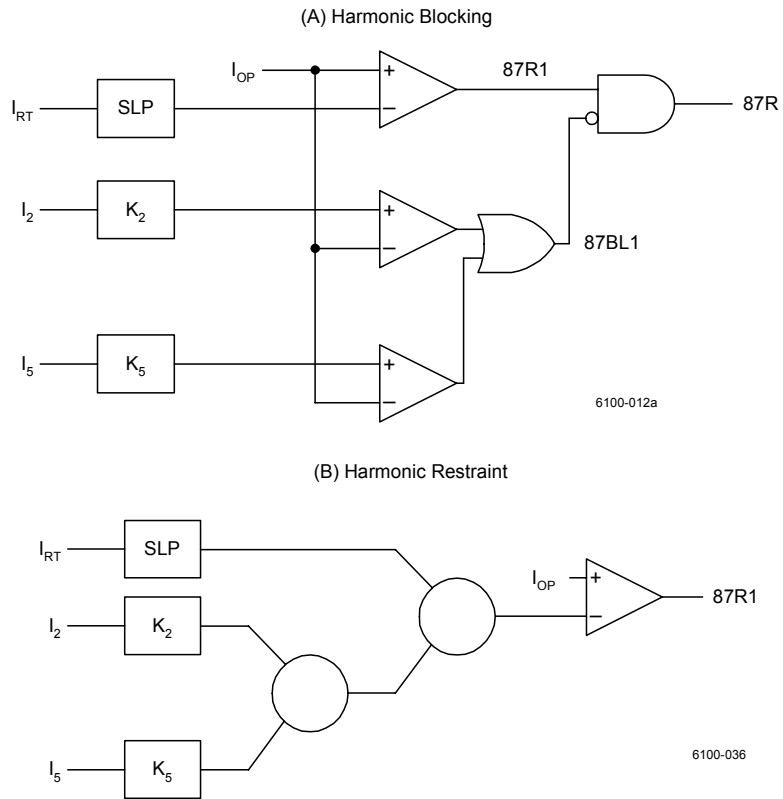

Figure 8 Two Approaches to a Differential Element

Figure 9 shows the three-phase versions of the transformer differential relay with independent harmonic blocking or restraint. The relay is composed of three differential elements of the types shown in Figure 8. In both cases a tripping signal results when any one of the relay elements asserts.

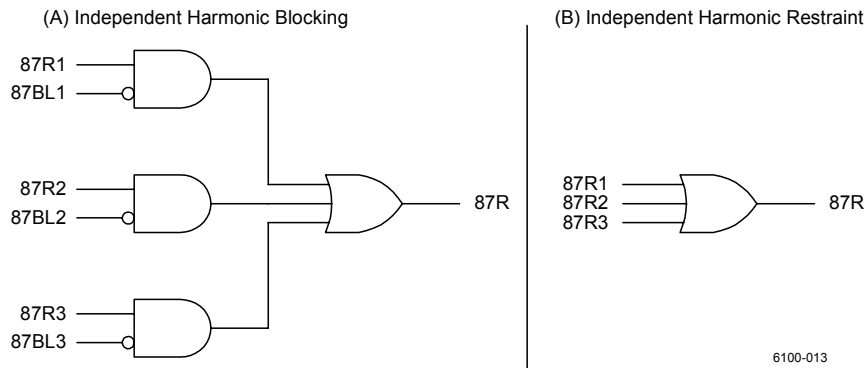

Figure 9 Three-Phase Differential Relay With: (A) Independent Harmonic Blocking and (B) Independent Harmonic Restraint

Note that in the harmonic restraint element (see Figure 8 (B)), the operating current, I_{OP} , should overcome the combined effects of the restraining current, I_{RT} , and the harmonics of the operating current. On the other hand, in the harmonic blocking element the operating current is independently compared with the restraint current and the harmonics. Table 2 summarizes the results of a qualitative comparison of the harmonic restraint (using all harmonics) and blocking methods for transformer differential protection.

The comparison results given in Table 2 suggest use of the blocking method, if security for inrush can be guaranteed. However, it is not always possible to guarantee security for inrush, as a later section of this paper explains. Therefore, harmonic restraint is an alternative method for providing relay security for inrush currents having low harmonic content.

Another alternative is to use common harmonic restraint or blocking. This method is simple to implement in a blocking scheme and is the preferred alternative in present-day digital relays. Figure 10 shows a logic diagram of the common harmonic blocking method.

Table 2 Comparison of Harmonic Restraint and Blocking Methods

	All-Harmonic Restraint (HR)	Blocking (HB)	Remarks
Security for External Faults	Higher	Lower	HR always uses harmonics from CT saturation for additional restraint. HB only blocks if the harmonic content is high.
Security for Inrush	Higher	Lower	HR adds the effects of percentage and harmonic restraint. HB evaluates the harmonics independently.
Security for Overexcitation	Higher	Lower	Same as above. However, a fifth-harmonic blocking scheme is the best solution, as will be shown in a later section.
Dependability	Lower	Higher	Harmonics from CT saturation reduce the sensitivity of HR for internal faults. Using only even harmonics solves this problem.
Speed	Lower	Higher	Percentage differential and harmonic blocking run in parallel in HB.
Slope Characteristic	Harmonic dependent	Well defined	HB slope characteristic is independent from harmonics.
Testing	Results depend upon harmonics	Straight forward	Same as above.

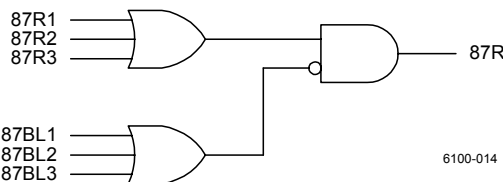

Figure 10 Common Harmonic Blocking Method

A method that provides a compromise in reliability between the independent and common harmonic blocking methods described earlier forms a composite signal that contains information on the harmonics of the operating currents of all relay elements. Comparison of this composite signal with the operating current determines relay operation.

The composite signal, I_{CH} , may be of the following form:

$$I_{CH} = \sqrt[3]{K_2 I_{2n} + K_3 I_{3n} + \dots} \quad \text{Equation 14}$$

I_{CH} may contain all or only part of the harmonics of the operating current. Another possibility is to calculate the RMS value of the harmonics for each relay element, I_{Hn} :

$$I_{Hn} = \sqrt{I_{2n}^2 + I_{3n}^2 + \dots} \quad \text{Equation 15}$$

We can then calculate the composite signal, I_{CH} , as an average value, using Equation 16 or Equation 17.

$$I_{CH} = \frac{1}{3} \sum_{n=1}^3 I_{Hn} \quad \text{Equation 16}$$

$$I_{CH} = \frac{1}{3} \sqrt[3]{\sum_{n=1}^3 I_{Hn}^2} \quad \text{Equation 17}$$

The relay blocking condition is the following:

$$I_{OP} < K_{CH} I_{CH} \quad \text{Equation 18}$$

Common harmonic blocking logic provides high security but sacrifices some dependability. Energization of a faulted transformer could result in harmonics from the inrush currents of the nonfaulted phases, and these harmonics could delay relay operation.

Wave Shape Recognition Methods

Other methods for discriminating internal faults from inrush conditions are based on direct recognition of the wave shape distortion of the differential current.

Identification of the separation of differential current peaks represents a major group of wave shape recognition methods. Bertula [37] designed an early percentage differential relay in which the contacts vibrated for inrush current (because of the low current intervals) and remained firmly closed for symmetrical currents corresponding to internal faults. Rockefeller [16] proposed blocking relay operation if successive peaks of the differential current fail to occur at about 7.5–10 ms.

A well-known principle [14], [38] recognizes the length of the time intervals during which the differential current is near zero. Figure 11 depicts the basic concept behind this low current detection method.

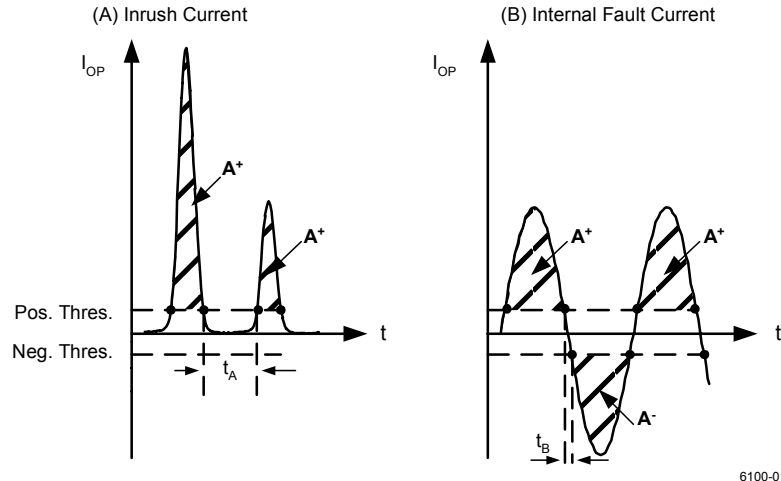

Figure 11 Differential Relay Blocking Based on Recognizing the Duration Time of Low Current Intervals

The differential current is compared with positive and negative thresholds having equal magnitudes. This comparison helps to determine the duration of the intervals during which the absolute value of the current is less than the absolute value of the threshold. The time intervals are then electronically compared with a threshold value equal to one-quarter cycle. For inrush currents (Figure 11 (A)) the low current intervals, t_A , are greater than one-quarter cycle, and the relay is blocked. For internal faults (Figure 11 (B)) the low current intervals, t_B , are less than one-quarter cycle, and the relay operates.

Using the components of the rectified differential current provides an indirect way to identify the presence of low current intervals. Hegazy [39] proposed comparing the second harmonic of the rectified differential current with a given threshold to generate a tripping signal. Dmitrenko [40] proposed issuing a tripping signal if the polarity of a summing signal remains unchanged. This signal is the sum of the dc and amplified fundamental components of the rectified differential current.

Another group of methods makes use of the recognition of dc offset or asymmetry in the differential current. Some early relays [15], [41], [42] used the saturation of an intermediate transformer by the dc offset of the differential current as a blocking method. A transient additional restraint based on the dc component was an enhancement to a well-known harmonic-restraint transformer differential relay [11]. Michelson [43] proposed comparing the amplitudes of the positive and negative semicycles of the differential current with given thresholds in two different polarized elements. Both elements must pick up to produce a trip. Rockefeller [16] suggested extension of this idea to a digital relay.

Another alternative [44] is to use the difference of the absolute values of the positive and negative semicycles of the differential current for restraint. More recently, Wilkinson [17] proposed making separate percentage-differential comparisons on both semicycles of the differential current. Tripping occurs if an operation condition similar to Equation 7 is true for both semicycles.

A NEW APPROACH FOR TRANSFORMER PROTECTION

The evaluation, in the previous section, of existing harmonic restraint/blocking methods makes clear that independent restraint/blocking methods may fail to ensure security for some real-life inrush conditions. Common harmonic restraint/blocking could provide solutions, but the behavior of these methods for internal faults combined with inrush currents requires further study.

Combining restraint and blocking into an independent restraint/blocking method provides a new approach to transformer differential protection. Even harmonics of the differential current provide restraint, while both the fifth harmonic and the dc component block relay operation.

Even-Harmonic Restraint

In contrast to the odd harmonics ac CT saturation generates, even harmonics are a clear indicator of magnetizing inrush. Even harmonics resulting from dc CT saturation are transient in nature. It is important to use even harmonics (and not only the second harmonic) to obtain better discrimination between inrush and internal fault currents.

Our tests suggest use of even harmonics (second and fourth) in a restraint scheme that ensures security for inrush currents having very low second-harmonic current. The operation equation is:

$$I_{OP} > SLP \cdot I_{RT} + K_2 I_2 + K_4 I_4 \quad \text{Equation 19}$$

Fifth-Harmonic Blocking

It is a common practice to use the fifth harmonic of the operation current to avoid differential relay operation for transformer overexcitation conditions [13]. In our opinion, the best solution is a harmonic blocking scheme in which there is independent fifth harmonic comparison with the operation current. In this scheme a given relay setting, in terms of fifth-harmonic percentage, always represents the same overexcitation condition. In a fifth-harmonic restraint scheme a given setting may represent different overexcitation conditions, depending on the other harmonics that may be present.

Relay tripping in this case requires fulfillment of Equation 19 and not Equation 13.

DC Blocking

The proposed method of even-harmonic restraint and fifth-harmonic blocking provides very high relay security for inrush and overexcitation conditions. There are, however, some inrush cases in which the differential current is practically a pure sine wave. One of the real cases we will analyze later exhibits such a behavior. Any harmonic-based method could cause relay misoperation in such extreme inrush cases.

The dc component of inrush current typically has a greater time constant than that for internal faults. The presence of dc offset in the inrush current is an additional indicator that can be used to guarantee relay security for inrush. This wave shape recognition method is relatively easy to apply in a digital relay, because extraction of the dc component is a low-pass filtering process.

We propose splitting the differential current into positive and negative semicycles and calculating one-cycle sums for both semicycles. We then propose using the ratio of these sums to block relay operation. The one-cycle sum of the positive semicycle is proportional to the area A^+ (see Figure 11); the one-cycle sum of the negative semicycle is proportional to the area A^- .

The following equations give the sum, S^+ , of the positive current samples:

$$S^+ = \left| \sum_{k=1}^N i_k \right| \rightarrow (i_k \geq \epsilon) \quad \text{Equation 20}$$

$$S^+ = 0 \rightarrow (i_k < \epsilon) \quad \text{Equation 21}$$

where i_k represents the current samples, N is the number of samples per cycle, and ϵ is a given threshold value. S^+ is proportional to the area A^+ of the positive semicycle of the operating current (see Figure 11).

The sum S^- of the negative current examples is given by:

$$S^- = \left| \sum_{k=1}^N i_k \right| \rightarrow (i_k \leq -\epsilon) \quad \text{Equation 22}$$

$$S^- = 0 \rightarrow (i_k > -\epsilon) \quad \text{Equation 23}$$

S^- is proportional to the area A^- of the negative semicycle in Figure 11. We calculate the dc ratio, DCR, according to Equation 24, to account for both positive and negative dc offsets:

$$\text{DCR} = \frac{\text{Min}(S^+, S^-)}{\text{Max}(S^+, S^-)} \quad \text{Equation 24}$$

Equation 24 gives a DCR value that is normalized (its value is always between 0 and 1) and also avoids division by zero.

By comparing DCR with a 0.1 threshold, we implement the relay dc blocking method:

$$\text{DCR} < 0.1 \quad \text{Equation 25}$$

Relay tripping requires the fulfillment of Equation 19, but neither Equation 13 nor Equation 25.

Selecting a value for the threshold in Equation 25 means deciding on a compromise between security and speed. A high value (near 1) affords high security but is detrimental to speed. From tests, we defined a value of 0.1 as a good solution. The delay is practically negligible for system X/R ratios as great as 40.

The response of this dc blocking method depends on the dc signal information apart from the harmonic content of the differential current. For example, the method ensures dependability for internal faults with CT saturation and maintains its security during inrush conditions with low even-harmonic content.

CURRENT DIFFERENTIAL RELAY

The relay consists of three differential elements. Each differential element provides percentage differential protection with independent even-harmonic restraint and fifth-harmonic and dc blocking. The user may select even-harmonic blocking instead of even-harmonic restraint. In such a case two blocking modes are available: 1) independent harmonic and dc blocking, and 2) common harmonic and dc blocking.

Data Acquisition, Filtering, Scaling, and Compensation

Figure 12 shows the block diagram of the data acquisition, filtering, scaling, and compensation sections for Winding 1 currents. The input currents are the CT secondary currents from Winding 1 of the transformer. The data acquisition system includes analog low-pass filters and analog-to-digital converters. The digitized current samples are the inputs to four digital band-pass filters. These filters extract the samples corresponding to the fundamental component and to the second, fourth, and fifth (not shown) harmonics of the input currents. A dc filter (not shown) also receives the current samples as inputs and forms the one-cycle sums of the positive and negative values of these samples. The outputs of the digital filters are then processed mathematically to provide the scaling and connection compensation that the power and current transformers require.

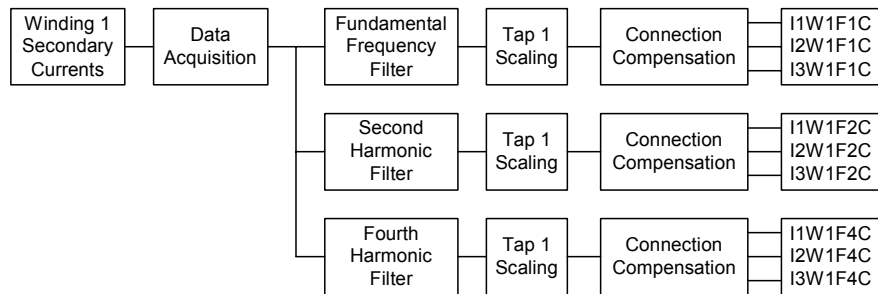

6100-016cv

Figure 12 Data Acquisition, Filtering, Scaling, and Compensation for Winding 1 Currents

Restraint Differential Element

Figure 13 shows a schematic diagram of one of the percentage differential elements with even-harmonic restraint (Element 1). Inputs to the differential element are the filtered, scaled, and compensated sets of samples corresponding to the fundamental component and second and fourth harmonics of the currents from each of the transformer windings. The magnitude of the sum of the fundamental component currents forms the operating current, $IOP1$, according to Equation 1. The scaled sum of the magnitudes of the fundamental component currents forms the restraint current, $IRT1$, according to Equation 3, with $k = 0.5$. The magnitudes of the sums of the second- and fourth-harmonic currents represent the second- ($IIF2$) and fourth- ($IIF4$) harmonic restraint currents.

Restraint current, $IRT1$, is scaled to form the restraint quantity $IRT1 \cdot f$ (SLP). Comparator 1 and switch S1 select the slope value as a function of the restraint current to provide a dual-slope percentage characteristic. Harmonic restraint currents are scaled to form the second- and fourth-harmonic restraint quantities. The scaling factors $100/PCT2$ and $100/PCT4$ correspond to K_2 and K_4 , respectively (Equation 19).

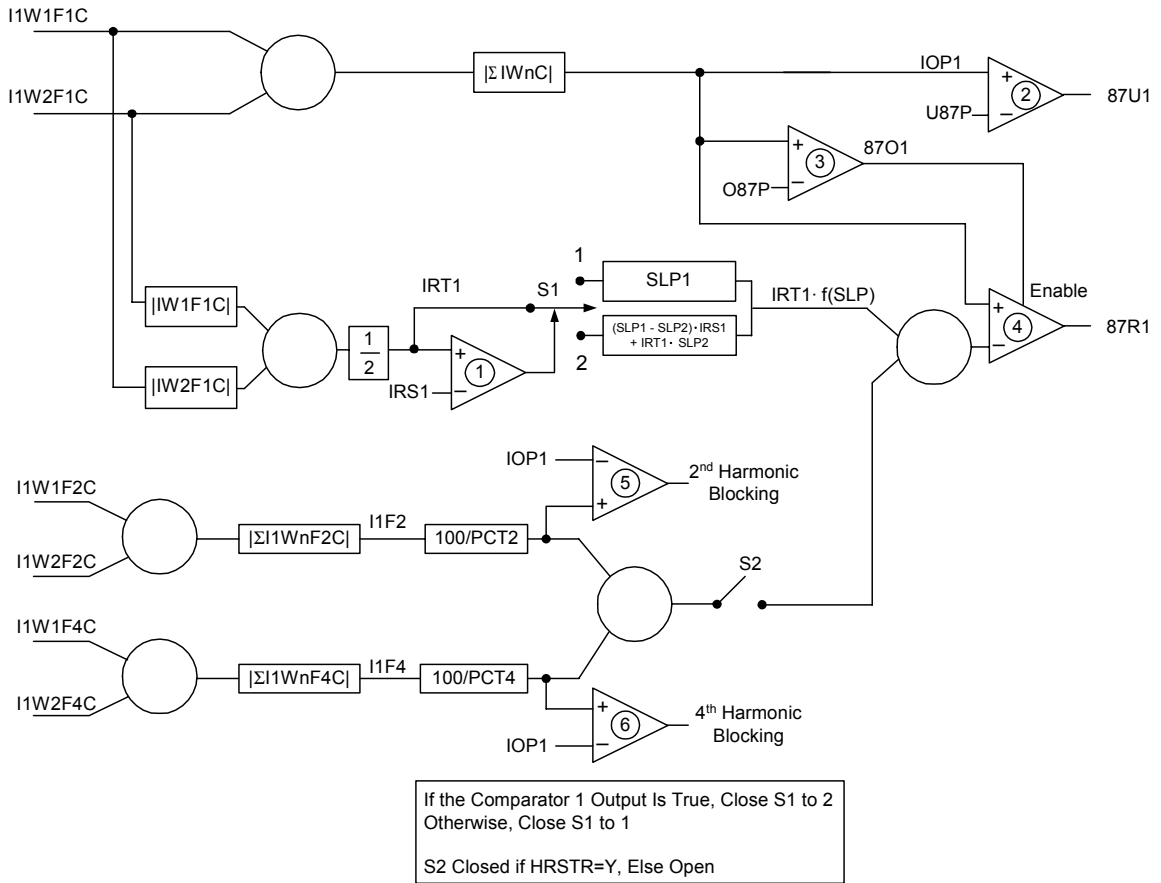

6100-017cv

Figure 13 Even-Harmonic Restraint, 87R1, and Unrestraint, 87U1, Differential Elements

Comparator 4 compares the operating current to the sum of the fundamental and harmonic restraint quantities. The comparator asserts for fulfillment of Equation 19. Comparator 3 enables Comparator 4 if the operating current, IOP1, is greater than a threshold value, O87P. Assertion of Comparator 3 provides the relay minimum pickup current, I_{PU} . Switch S2 permits enabling or disabling of even-harmonic restraint in the differential element.

Comparators 5 and 6 compare the operating current to the second- and fourth-harmonic restraint quantities, respectively, to generate the second- and fourth-harmonic blocking signals. Comparison of the operating current with the fifth-harmonic restraint quantity (not shown) permits generation of the fifth-harmonic blocking signal (5HB1).

The differential element includes an unrestrained instantaneous differential overcurrent function. Comparator 2, which compares the operating current, IOP1, with a threshold value, U87P, provides the unrestrained differential overcurrent function.

Figure 14 depicts the operating characteristic of the restraint differential element. The characteristic can be set as either a single-slope, percentage differential characteristic or as a dual-slope, variable percentage differential characteristic. Figure 14 shows recommended setting values.

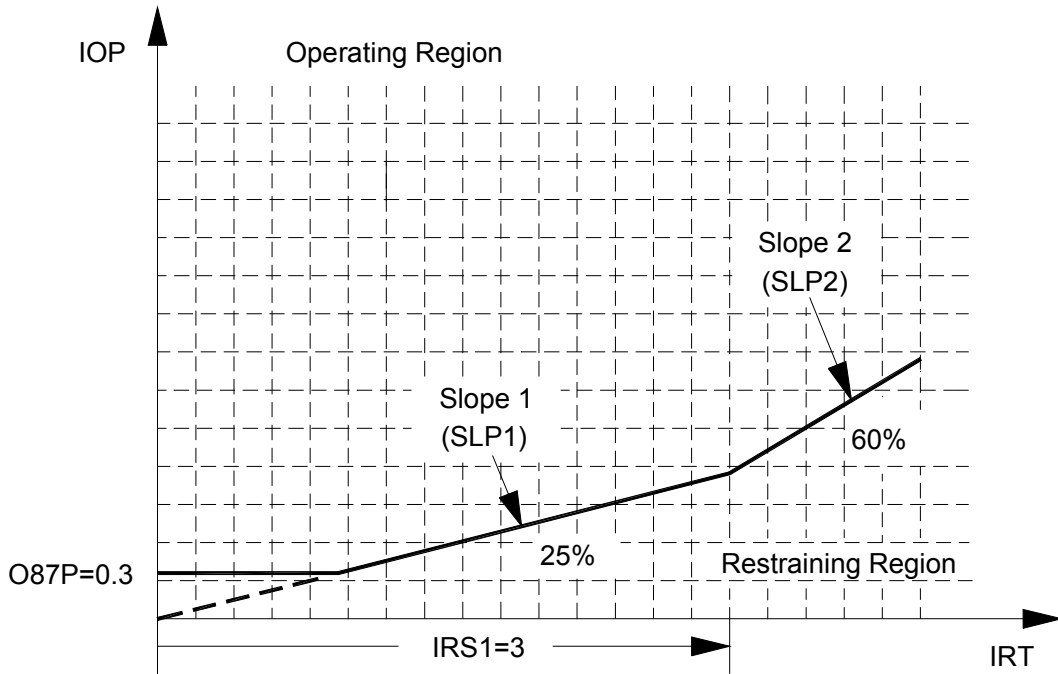

DWG: M3871028a

Figure 14 Percentage Restraint Differential Characteristic

DC Filtering and Blocking Logic

Figure 15 shows a schematic diagram of the dc blocking logic for Element 1. We form the positive, S^+ , and negative, S^- , one-cycle sums of the differential current. We then determine the minimum and the maximum of the absolute values of the two one-cycle sums and calculate the dc ratio, DCR, by dividing the minimum one-cycle sum value by the maximum one-cycle sum value. When DCR is less than a threshold value of 0.1, the relay issues a blocking signal, DCBL1. Then, the relay blocking condition is according to Equation 25.

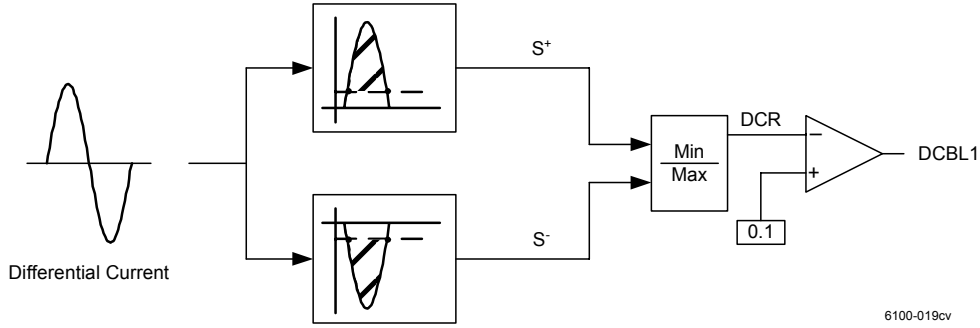

6100-019cv

Figure 15 DC Blocking Logic

By defining DCR as the ratio of the minimum to the maximum values of the one-cycle sums, we account for differential currents having positive or negative dc offset components. In addition, the resulting DCR value is normalized.

Relay tripping requires the fulfillment of Equation 19, but neither Equation 13 nor Equation 25.

Relay Blocking Logic

Figure 16 depicts the blocking logic of the differential elements. If the even-harmonic restraint is not in use, switch S1 closes to add even-harmonic blocking to the fifth-harmonic and dc blocking functions. In this case the differential elements operate in a blocking-only mode. Switches S2, S3, S4, and S5 permit enabling or disabling each of the blocking functions. The output (87BL1) of the differential element blocking logic asserts when any one of the enabled logic inputs asserts.

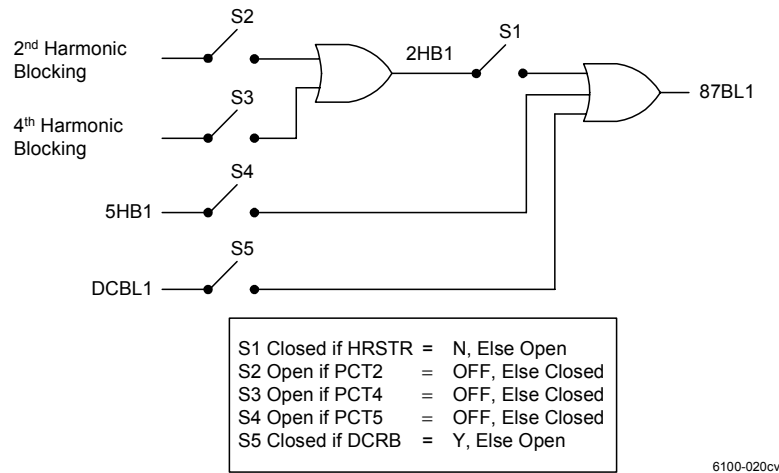

Figure 16 Differential Element Blocking Logic

Figure 17 shows the blocking logic of the differential relay. You can set the relay to an independent blocking mode (IHBL=Y) or a common blocking mode (IHBL=N).

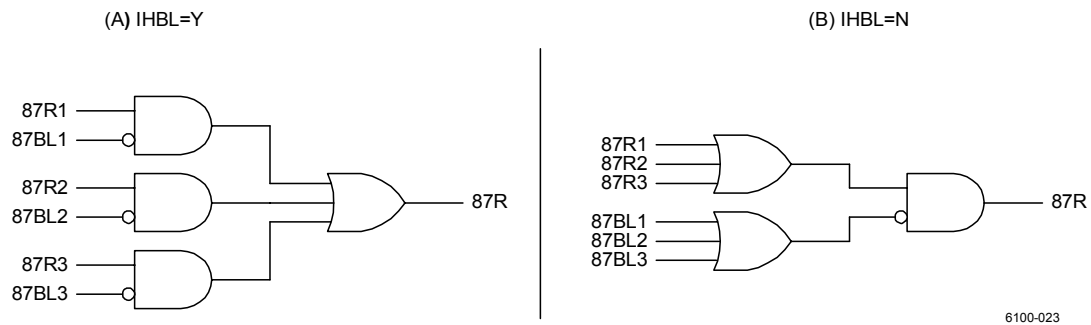

Figure 17 Differential Relay Blocking Logic

DIFFERENTIAL ELEMENT PERFORMANCE DURING INRUSH CONDITIONS

Let us study the performance of the differential elements for three field cases of transformer energization. These cases are special because they cause some of the traditional differential elements to misoperate, as we will see below.

Case 1

Figure 18 shows a transformer energization case while A-phase is faulted and the transformer is not loaded. The transformer is a three-phase, delta-wye-connected distribution transformer; the CT connections are wye at both sides of the transformer.

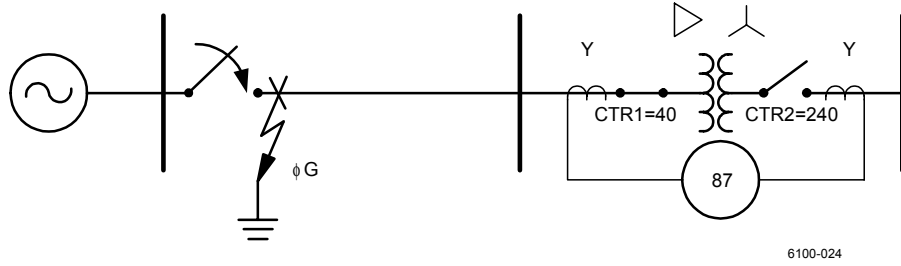

Figure 18 Transformer Energization While A-Phase Is Faulted

Figure 19 shows the differential Element 1 inrush current; this element uses I_{AB} current. This signal looks like a typical inrush current. Let us analyze the signal characteristics.

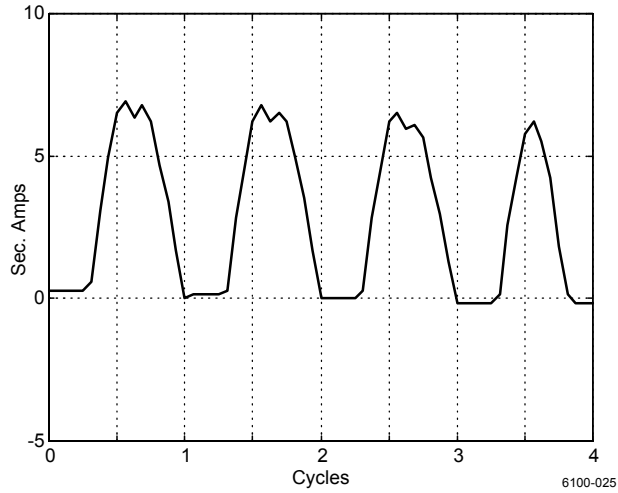

Figure 19 Element 1 High-Side Winding Current, I_{AB} , Recorded While Energizing the Transformer With an A-Phase External Fault

The current signal has low second-harmonic content and high dc content compared to the fundamental. Note that this signal also has high third-harmonic content. Figure 20 shows the second, third, and fourth harmonics as percentages of fundamental. Notice that the second harmonic drops below five percent.

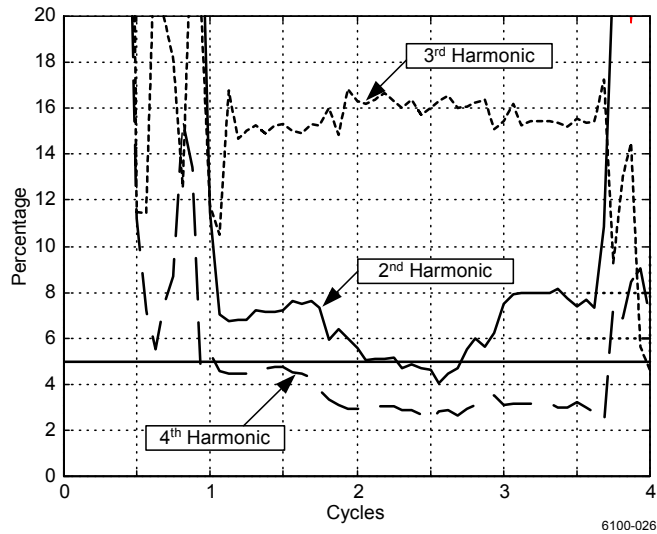

Figure 20 Second, Third, and Fourth Harmonics as Percentages of Fundamental of the Inrush Current Where the Third-Harmonic Content Is Greater Than the Even-Harmonic Content

Figure 21 shows the dc content as a percentage of fundamental of the inrush current. The dc content is high during the event; this is useful information for adding security to the differential relay.

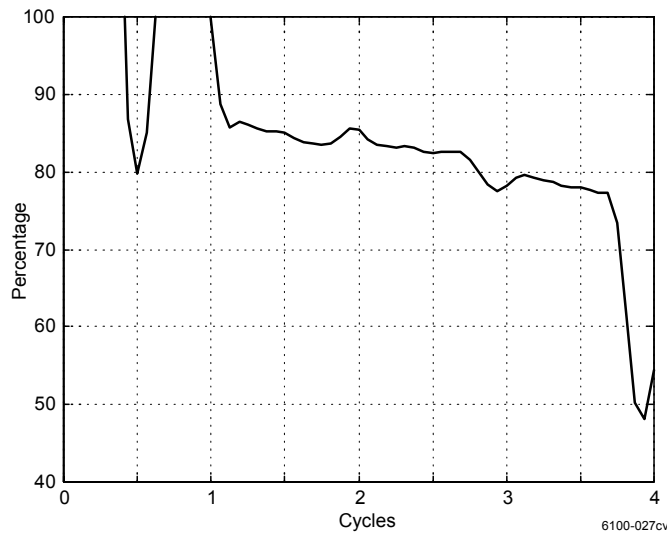

Figure 21 DC Component as Percentage of the RMS Value of Fundamental During Inrush Conditions

The differential elements operate as follows:

Second- and Fourth-Harmonic Blocking

The low second- and fourth-harmonic content produces misoperation of the differential element that uses independent harmonic blocking.

All-Harmonic Restraint

The harmonic restraint relay that uses all harmonics maintains its security because of the high third-harmonic content of the inrush current.

Low Current Detection

The waveform has a low differential current section that lasts one-quarter of a cycle each cycle, the minimum time that the element requires for blocking; this element marginally maintains its security.

Second- and Fourth-Harmonic Restraint

The low second- and fourth-harmonic content produces misoperation of the differential element that uses independent harmonic restraint.

DC Ratio Blocking

The ratio of the positive to the negative dc value is zero, so this element properly blocks the differential element.

Case 2

This case is similar to Case 1, but differs in that the transformer is loaded while being energized with reduced A-phase voltage. Figure 22 shows the delta-wye distribution transformer; the CT connections are wye and delta to compensate for transformer phase shift. In this application, the differential relay does not need to make internal phase shift compensation.

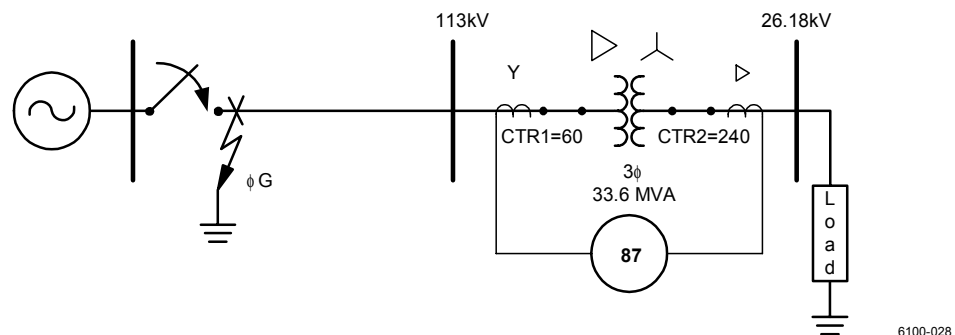

Figure 22 Transformer Energization While A-Phase Is Faulted and the Transformer Is Loaded

Figure 23 shows the differential Element 1 inrush current from the high- and low-side transformer windings after relay scaling. The two signals are 180° out of phase, but they have different instantaneous values. These values create the differential current shown in Figure 24.

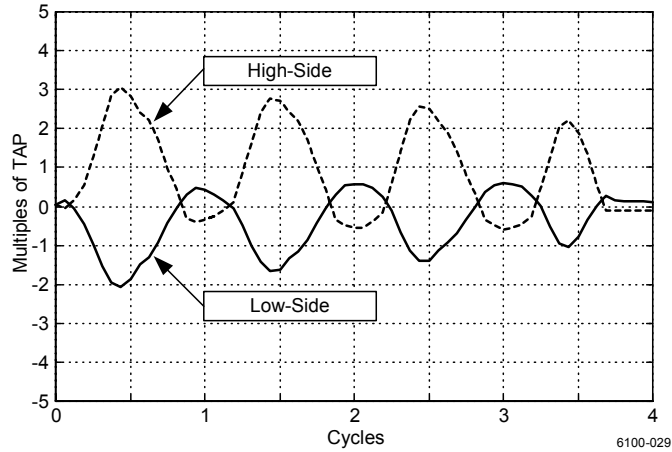

Figure 23 Element 1 Inrush Currents from the High- and Low-Side Transformer Windings After Relay Scaling

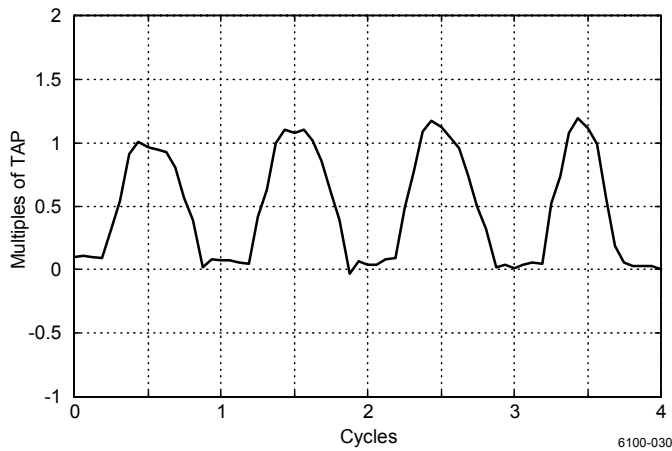

Figure 24 Differential Current During Transformer Energization With the Power Transformer Loaded

Figure 25 and Figure 26 show the harmonic and dc content, respectively, of the differential current as a percentage of fundamental. This signal has a second-harmonic content that drops to seven percent while the fourth harmonic drops to approximately 10 percent. In this case the even harmonics, especially the fourth, provide information to properly restrain or block the differential element. The dc content also provides information that adds security to the differential element.

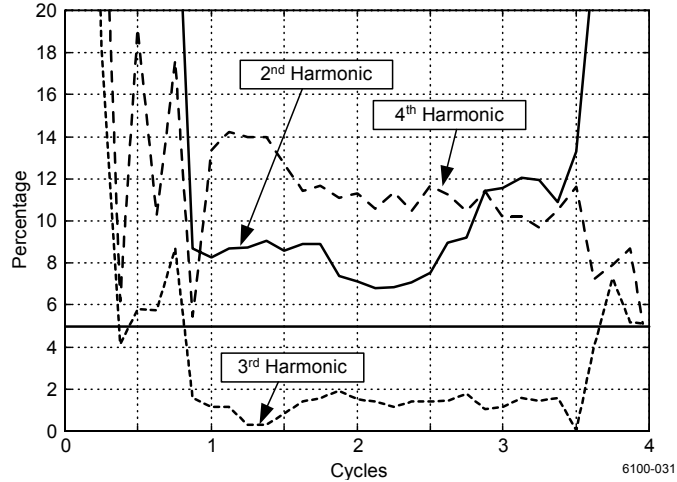

Figure 25 When the Loaded Transformer Is Energized With Reduced Voltage, the Fourth Harmonic Provides Information to Restrain or Block the Differential Element

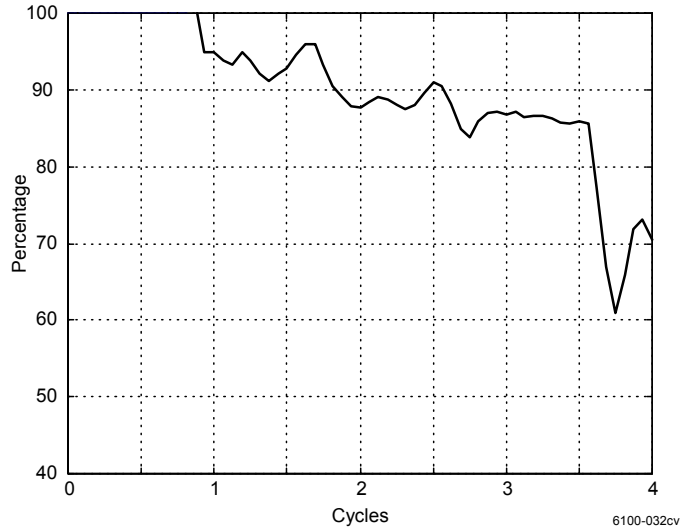

Figure 26 DC Content of the Differential Current for Case 2

The differential elements operate as follows:

Second- and Fourth-Harmonic Blocking

The second and fourth harmonics properly block the differential element. Notice that the second-harmonic percentage must be set to six percent for independent harmonic blocking applications.

All-Harmonic Restraint

The harmonic restraint relay that uses all harmonics maintains its security because of the even-harmonic content of the signal.

Low Current Detection

The waveform has a low differential current section that lasts longer than one-quarter cycle, so this logic properly blocks the differential element.

Second- and Fourth-Harmonic Restraint

The even-harmonic content of the signal restrains the differential relay from tripping.

DC Ratio Blocking

The ratio of the positive to the negative dc value is zero, so this element properly blocks the differential element.

Case 3

Figure 27 shows a field case of the energization during commissioning of a three-phase, 180 MVA, 230/138 kV autotransformer. The autotransformer connection is wye-wye; the CTs are connected in delta at both sides of the autotransformer.

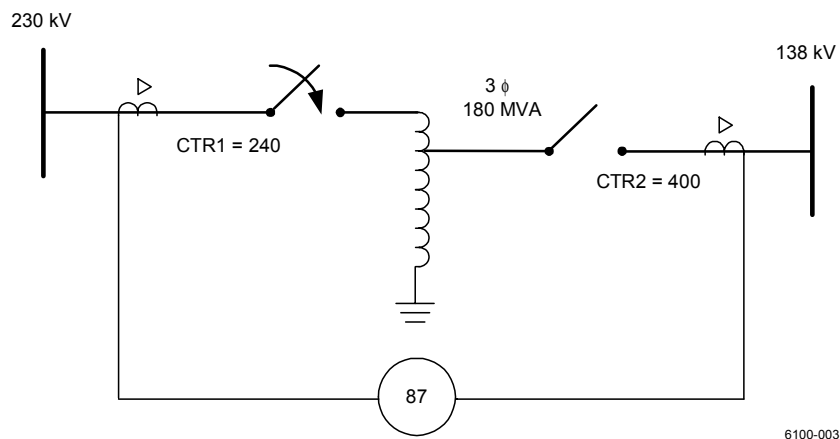

Figure 27 Transformer Energization During Commissioning

Figure 28 shows the relay secondary currents from the autotransformer high side. These currents result from autotransformer energization with the low-side breaker open. The currents are typical inrush waves with a relatively small magnitude. Notice that the signal low current intervals last less than one-quarter cycle.

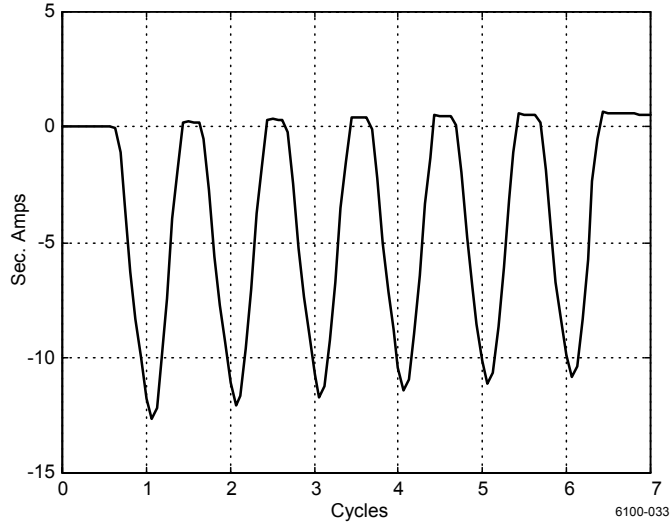

Figure 28 Inrush Current With Low Current Intervals Lasting Less Than One-Quarter Cycle

Figure 29 shows the harmonic content of the inrush current. We can see that the inrush current has a relatively small second-harmonic percentage, which drops to approximately nine percent.

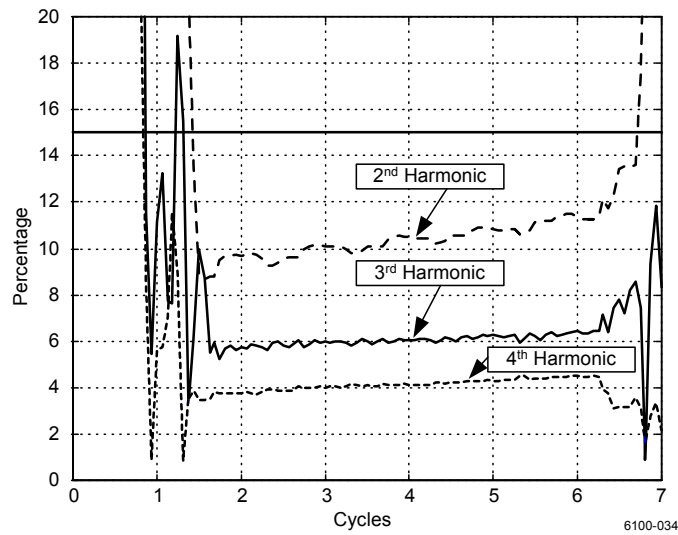

Figure 29 Second-Harmonic Percentage Drops to Approximately Nine Percent

As in previous cases, Figure 30 shows that the dc content of the inrush current is high during the event.

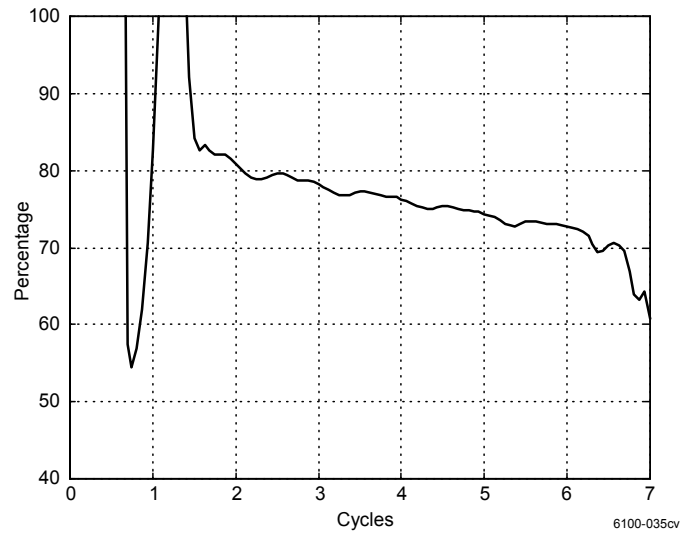





Figure 30 DC Content of the Differential Current for Case 3

All differential elements except the low current detector operate correctly for this case. The low current zone in this case lasts less than the one-quarter cycle required to determine blocking conditions.

Table 3 summarizes the performance of the different inrush detection methods discussed earlier.

Table 3 Inrush Detection Methods Performance During Inrush Conditions

Method	Case 1	Case 2	Case 3
Second- and Fourth-Harmonic Blocking	Low even-harmonic content	Second-harmonic setting 6%	Second-harmonic setting 8%
All-Harmonic Restraint	High third-harmonic content	Even-harmonic content	Harmonic content
Low Current Detection	Low Current Interval = $\frac{1}{4}$ cycle	Low Current Interval > $\frac{1}{4}$ cycle	 Low Current Interval < $\frac{1}{4}$ cycle
Even-Harmonic Restraint	 Low even-harmonic content	Even-harmonic content	Even-harmonic content
DC Ratio Blocking	DC ratio = zero	DC ratio > 0.1 after 1 cycle	DC ratio = zero

Note:  = Inrush Condition Detection;
 = No Inrush Condition Detection.

The all-harmonic restraint method performs correctly for all three cases. This method sacrifices relay dependability during symmetrical CT saturation conditions. Combining the even-harmonic restraint method and the dc ratio blocking method provides a good compromise of speed and reliability.

CONCLUSIONS

1. Most transformer differential relays use the harmonics of the operating current to distinguish internal faults from magnetizing inrush or overexcitation conditions. The harmonics can be used to restrain or to block relay operation. Harmonic restraint and blocking methods ensure relay security for a very high percentage of inrush and overexcitation cases. However, these methods do not work for cases with very low harmonic content in the operating current.
2. Common harmonic restraint or blocking increases differential relay security, but could delay relay operation for internal faults combined with inrush currents in the nonfaulted phases.
3. Wave shape recognition techniques represent another alternative for discriminating internal faults from inrush conditions. However, these techniques fail to identify transformer overexcitation conditions.
4. A new approach that combines harmonic restraint and blocking methods with a wave shape recognition technique provides added security to the independent harmonic restraint element

without sacrificing dependability. This new method uses even harmonics for restraint, plus dc component and fifth harmonic for blocking.

5. Using even-harmonic restraint ensures security for inrush currents with low second-harmonic content and maintains dependability for internal faults with CT saturation. The use of fifth-harmonic blocking guarantees an invariant relay response to overexcitation. Using dc offset blocking ensures security for inrush conditions with very low total harmonic distortion.

REFERENCES

- [1] E. A. Klingshirn, H. R. Moore, and E. C. Wentz, "Detection of Faults in Power Transformers," *AIEE Transactions*, Vol. 76, Part III, April 1957, pp. 87–95.
- [2] J. T. Madill, "Typical Transformer Faults and Gas Detector Relay Protection," *AIEE Transactions*, Vol. 66, 1947, pp. 1052–1060.
- [3] R. L. Bean and H. L. Cole, "A Sudden Gas Pressure Relay for Transformer Protection," *AIEE Transactions*, Vol. 72, Part III, June 1953, pp. 480–483.
- [4] I. T. Monseth and P. H. Robinson, *Relay Systems: Theory and Applications*, New York: McGraw Hill Co., 1935.
- [5] H. P. Sleeper, "Ratio Differential Relay Protection," *Electrical World*, October 1927, pp. 827–831.
- [6] R. E. Cordray, "Percentage Differential Transformer Protection," *Electrical Engineering*, Vol. 50, May 1931, pp. 361–363.
- [7] R. E. Cordray, "Preventing False Operation of Differential Relays," *Electrical World*, July 25, 1931, pp. 160–161.
- [8] E. L. Harder and W. E. Marter, "Principles and Practices of Relaying in the United States," *AIEE Transactions*, Vol. 67, Part II, 1948, pp. 1005–1023.
- [9] L. F. Kennedy and C. D. Hayward, "Harmonic-Current-Restrained Relays for Differential Protection," *AIEE Transactions*, Vol. 57, May 1938, pp. 262–266.
- [10] C. D. Hayward, "Harmonic-Current-Restrained Relays for Transformer Differential Protection," *AIEE Transactions*, Vol. 60, 1941, pp. 377–382.
- [11] C. A. Mathews, "An Improved Transformer Differential Relay," *AIEE Transactions*, Vol. 73, Part III, June 1954, pp. 645–650.
- [12] R. L. Sharp, and W. E. Glassburn, "A Transformer Differential Relay With Second-Harmonic Restraint," *AIEE Transactions*, Vol. 77, Part III, Dec. 1958, pp. 913–918.
- [13] C. H. Einval and J. R. Linders, "A Three-Phase Differential Relay for Transformer Protection," *IEEE Transactions PAS*, Vol. PAS-94, No. 6, Nov/Dec 1975, pp. 1971–1980.
- [14] A. M. Dmitrenko, "Semiconductor Pulse-Duration Differential Restraint Relay," *Izvestiya Vysshikh Uchebnykh Zavedenii, Elektromekhanika*, No. 3, March 1970, pp. 335–339 (in Russian).

- [15] G. I. Atabekov, *The Relay Protection of High Voltage Networks*, London: Pergamon Press Ltd., 1960.
- [16] G. D. Rockefeller, "Fault Protection With a Digital Computer," *IEEE Transactions PAS*, Vol. PAS-98, April 1969, pp. 438–464.
- [17] S. B. Wilkinson, *Transformer Differential Relay*, U.S. Patent No 5627712, May 6, 1997.
- [18] C. D. Hayward, "Prolonged Inrush Currents With Parallel Transformers Affect Differential Relaying," *AIEE Transactions*, Vol. 60, 1941, pp. 1096–1101.
- [19] L. F. Blume, G. Camilli, S. B. Farnham, and H. A. Peterson, "Transformer Magnetizing Inrush Currents and Influence on System Operation," *AIEE Transactions*, Vol. 63, 1944, pp. 366–375.
- [20] T. R. Specht, "Transformer Magnetizing Inrush Current," *AIEE Transactions*, Vol. 70, Part I, 1951, pp. 323–328.
- [21] AIEE Committee Report, "Report on Transformer Magnetizing Current and Its Effect on Relaying and Air Switch Operation," *AIEE Transactions*, Vol. 70, Part II, 1951, pp. 1733–1740.
- [22] W. K. Sonnemann, C. L. Wagner, and G. D. Rockefeller, "Magnetizing Inrush Phenomena in Transformer Banks," *AIEE Transactions*, Vol. 77, Part III, October 1958, pp. 884–892.
- [23] J. Berdy, W. Kaufman, and K. Winick, "A Dissertation on Power Transformer Excitation and Inrush Characteristics," *Symposium on Transformer Excitation and Inrush Characteristics and Their Relationship to Transformer Protective Relaying*, Houston, TX, August 5, 1976.
- [24] S. E. Zocholl, A. Guzmán, D. Hou, "Transformer Modeling as Applied to Differential Protection," *22nd Annual Western Protective Relay Conference*, Spokane, WA, October 24-26, 1995.
- [25] Cooper Power Systems, *Electric Power System Harmonics: Design Guide*, October 1990.
- [26] J. E. Waldron and S. E. Zocholl, "Design Considerations for a New Solid-State Transformer Differential Relay With Harmonic Restraint," *Fifth Annual Western Protective Relay Conference*, Sacramento, CA, October 15–18, 1978.
- [27] D. E. Marshall and P. O. Langguth, "Current Transformer Excitation Under Transient Conditions," *AIEE Transactions*, Vol. 48, No. 4, October 1929, pp. 1464–1474.
- [28] E. C. Wentz and W. K. Sonnemann, "Current Transformers and Relays for High-Speed Differential Protection With Particular Reference to Offset Transient Currents," *AIEE Transactions*, Vol. 59, August 1940, pp. 481–488.
- [29] C. Concordia and F. S. Rothe, "Transient Characteristics of Current Transformers During Faults," *AIEE Transactions*, Vol. 66, 1947, pp. 731–734.
- [30] IEEE Power Engineering Society, *Transient Response of Current Transformers*, IEEE Special Publication 76 CH 1130–4 PWR, January 1976.
- [31] IEEE Std C37.110–1996, *IEEE Guide for the Application of Current Transformers Used for Protective Relaying Purposes*.

- [32] J. A. Sykes, "A New Technique for High Speed Transformer Fault Protection Suitable for Digital Computer Implementation," *IEEE Paper No. C72 429-9*, Power Engineering Society Summer Meeting, 1972.
- [33] J. S. Thorp and A. G. Phadke, "A Microprocessor Based, Voltage-Restrained, Three-Phase Transformer Differential Relay," *Proceedings of the Southeastern Symposium on System Theory*, April 1982, pp. 312–316.
- [34] J. S. Thorp and A. G. Phadke, "A New Computer Based, Flux Restrained, Current Differential Relay for Power Transformer Protection," *IEEE Transactions PAS*, Vol. PAS–102, No. 11, November 1983, pp. 3624–3629.
- [35] K. Inagaki, M. Higaki, Y. Matsui, K. Kurita, M. Suzuki, K. Yoshida, and T. Maeda, "Digital Protection Method for Power Transformers Based on an Equivalent Circuit Composed of Inverse Inductance," *IEEE Transactions on Power Delivery*, Vol. 3, No. 4, October 1998, pp. 1501–1510.
- [36] General Electric Co., *Transformer Differential Relay With Percentage and Harmonic Restraint Types BDD 15B, BDD16B*, Document GEH-2057F.
- [37] G. Bertula, "Enhanced Transformer Protection Through Inrush-Proof Ratio Differential Relays," *Brown Boveri Review*, Vol. 32, 1945, pp. 129–133.
- [38] A. Giuliante and G. Clough, "Advances in the Design of Differential Protection for Power Transformers," *1991 Georgia Tech. Protective Relaying Conference*, Atlanta, GA, May 1–3, 1991, pp. 1–12.
- [39] M. Hegazy, "New Principle for Using Full-Wave Rectifiers in Differential Protection of Transformers," *IEE Proceedings*, Vol. 116, March 1969, pp. 425–428.
- [40] A. M. Dmitrenko, "The Use of Currentless Pauses for Detuning Differential Protection From Transient Imbalance Currents," *Elektrichestvo*, No. 1, January 1979, pp. 55–58 (in Russian).
- [41] D. Robertson (Editor), *Power System Protection Reference Manual—Reyrolle Protection*, London: Oriel Press Ltd., 1982.
- [42] R. K. Edgeley and F. L. Hamilton, "The Application of Transducers as Relays in Protective Gear," *IEE Proceedings*, Vol. 99, Part II, 1952, p. 297.
- [43] E. L. Michelson, "Rectifier Relay for Transformer Protection," *AIEE Transactions*, Vol. 64, May 1945, pp. 252–254.
- [44] E. V. Podgornyi and E. M. Ulianitskii, "A Comparison of Principles for Detuning Differential Relays From Transformer Inrush Currents," *Elektrichestvo*, No. 10, October 1969, pp. 26–32 (in Russian).

BIOGRAPHIES

Armando Guzmán received his BSEE with honors from Guadalajara Autonomous University (UAG), Mexico, in 1979. He received a diploma in fiber-optics engineering from Monterrey Institute of Technology and Advanced Studies (ITESM), Mexico, in 1990. He served as regional supervisor of the Protection Department in the Western Transmission Region of the Federal Electricity Commission (the electrical utility company of Mexico) for 13 years. He lectured at UAG in power system protection. Since 1993 he has been with Schweitzer Engineering Laboratories, Pullman, Washington, where he is presently a research engineer. He holds several patents in power system protection. He is a member of IEEE and has authored and coauthored several technical papers.

Stanley (Stan) Zocholl has a B.S. and M.S. in Electrical Engineering from Drexel University. He is an IEEE Life Fellow and a member of the Power Engineering Society and the Industrial Application Society. He is also a member of the Power System Relaying Committee and past chair of the Relay Input Sources Subcommittee. He joined Schweitzer Engineering Laboratories in 1991 in the position of Distinguished Engineer. He was with ABB Power T&D Company Allentown (formerly ITE, Gould, BBC) since 1947 where he held various engineering positions including Director of Protection Technology.

His biography appears in *Who's Who in America*. He holds over a dozen patents associated with power system protection using solid state and microprocessor technology and is the author of numerous IEEE and protective relay conference papers. He received the Best Paper Award of the 1988 Petroleum and Chemical Industry Conference and the Power System Relaying Committee's Distinguished Service Award in 1991.

Gabriel Benmouyal received his B.A.Sc. in Electrical Engineering and his M.A.Sc. in Control Engineering from Ecole Polytechnique, Université de Montréal, Canada in 1968 and 1970, respectively. In 1969 he joined Hydro-Québec as an instrumentation and control specialist. He worked on different projects in the field of substation control systems and dispatching centres. In 1978 he joined IREQ, where his main field of activity was the application of microprocessors and digital techniques to substation and generating-station control and protection systems. In 1997 he joined Schweitzer Engineering Laboratories in the position of Research Engineer. He is a registered professional engineer in the Province of Québec, is an IEEE member, and has served on the Power System Relaying Committee since May 1989.

Hector J. Altuve received his BSEE from Central University of Las Villas (UCLV), Cuba, in 1969 and his PhD from Kiev Polytechnic Institute, USSR, in 1981. He served as a professor in the School of Electrical Engineering at UCLV from 1969 to 1993. Since 1993 he has been a professor in the PhD program of the Mechanical and Electrical Engineering School at Autonomous University of Nuevo Leon, in Monterrey, Mexico. He is a member of the Mexican National Research System, a senior member of IEEE, and a PES Distinguished Lecturer. He has authored and coauthored many technical papers. He was the 1999-2000 Schweitzer Visiting Professor at Washington State University.